

**VIBRATORY SOIL COMPACTOR
1110EX-D | 1110EX-PD**

CASE
CONSTRUCTION



**RELIABLE & EFFECTIVE
COMPACTION**

CaseCE.com
EXPERTS FOR THE REAL WORLD
SINCE 1842

1110EX-D COMPACTOR



HIGH EFFICIENCY **Tier 3 engine**

The 1110EX-D compactor features the new powerful 4-cylinder, water cooled Tier 3 engine that delivers **22% more torque**. With more than 3 million units operating all over the world, including the CASE 770EX, 770EX Magnum and 851EX Loader Backhoes, the engine assures an excellent reliability. The turbocharged engine is equipped with an air after-cooler system with internal EGR that increases the density of the intake air, improving efficiency and reducing fuel consumption. Coupled with the turbo pre-cleaner, the water cooled engine ensures excellent cooling and lowest fuel consumption in its category.



HIGH RELIABILITY **For a durable performance**

Well-proven compaction technology: high manufacturing quality standards achieved with an experience spanning **over 2 decades of leadership** in India.

- **4-pins central joints:** a **heavy duty design** solution to make the machine suitable for the most severe applications
- **Turbo pre-cleaner:** mounted on top of the engine compartment: only fresh air is delivered to the engine to assure **perfect combustion**
- **Shock absorbers:** low vibrations transmitted by the drum to the machine components to **increase durability**



FIRST-RATE PRODUCTIVITY **Customized for various applications**

1110 EX vibratory soil compactor is available in two configurations to meet every surface compaction need.

- 1110 EX-D with **drum drive and increased traction** on slopes and landfills
- 1110 EX-PD with **clamp-on pad foot and drum drive** for compacting more cohesive materials such as clay and silt

The drum drive system features an additional high torque drive motor mounted on the front drum frame, resulting in excellent gradeability (36% continuous and 40% intermittent) and optimized traction.



HIGH VERSATILITY **Ready for every mission**

2 vibration stages provided by a variable displacement bi-directional axial piston pump with electrical displacement control allow effective compaction on a wide range of soil types.

- Great maneuverability: +/- 15° drum oscillating angle 37° steering angle » short steering radius
- Low steering effort » reduced operator fatigue
- Perfect match of vibration frequency and amplitude with soil for best performance
- Optimal dimensions for easy transportability



1110EX-D COMPACTOR



COMFORTABLE AND SAFE OPERATOR STATION **Easy access and excellent visibility**

- 90° clockwise rotating seat offers good visibility of rear wheels and front drum in every pass
- Easy and safe access to operator station, thanks to the wide steps and robust handles
- Closed ROPS/FOPS HVAC Cabin for excellent operator comfort and safety
- Operator station mounted on rubberized shock absorbers to minimize transmitted vibrations
- 2 front lights + 2 head lamps and 2 rear work lamps as standard for excellent visibility



SAFE AND EASY MAINTENANCE **Reduced downtime and operating costs**

- Easy access from ground level to battery and all main service items » thanks to the **single piece engine hood**
- Optimized engine layout facilitates the access to the hydraulic components

MAIN REASONS TO CHOOSE THE 1110EX-D



FIRST-RATE PRODUCTIVITY

- Perfect match of frequency and amplitude in vibration
- Cross-bar as a load-bearing structure for greater strength and more weight at the front
- The 32 mm thick drum shell provides excellent resistance and uniformity in compaction operations



HIGH RELIABILITY

- Standard turbo pre-cleaner
- Heavy-duty drum support frame
- World-class components



COMFORTABLE AND SAFE OPERATOR STATION

- Easy and safe cab access
- 90° clockwise rotating seat
- Closed ROPS/FOPS HVAC Cabin for excellent operator comfort and safety



The centrifugal force is generated by an internal eccentric shaft and a rotating mass: depending on the direction of rotation, the rotating mass is in phase with the eccentric shaft for a maximum centrifugal force or in the opposite position, for a minimum centrifugal force.



HIGH EFFICIENCY

- Turbocharged engine
- Air after-cooler system
- Higher intake air density
- Improved efficiency
- Reduced fuel consumption



SAFE AND EASY MAINTENANCE

Daily and regular maintenance is easily possible from ground level, thanks to the single-piece tilting hood. Reduced downtime and operating costs result in more productivity and better profitability.

1110EX-D COMPACTOR

SPECIFICATIONS

ENGINE

Make	FPT
Model	S 8000 - TIER III
Type	4 stroke turbocharged aftercooled
Cylinders	4
Bore/stroke	104 x 115
Displacement (l)	3.9
Fuel injection	Direct
Fuel	High speed diesel
Fuel filter	Spin-on type
Air intake	Turbocharged with internal EGR
Air filter	Dry type with dual element
Engine oil filter	Spin-on type
Cooling	Liquid
Engine speeds (no load)	
- Low:	950±50
- High:	2150±25
Max. power (hp)	110
(@rpm)	2300
(ISO3046)	
Max. torque (Nm)	430
(@rpm)	1400

VIBRATION SYSTEM

Type	Variable displacement bi-directional axial piston pump with electrical displacement control
Drive to vibration pump	Mechanical
Engine to pump ratio	Direct drive 1:1
Displacement (cc/rev)	34.4
Charge pressure (bar)	27
Vibration motor	Fixed displacement mounted on drum

STEERING

Steering system	Articulated hydrostatic steering
Steering angle	37° on either side (74° between stop to stop)
Turning radius (inner radius) (m)	3.65
Drum oscillation angle	15°
Tyre size	23.1/18-26 8 PR

ELECTRICAL SYSTEM

Alternator output (A)	65
Battery (V/Ah)	12 / 130

SERVICE CAPACITIES

Fuel tank (l)	235
Hydraulic tank (l)	70
Engine crank case (l)	9.1
Engine coolant (l)	15

PROPULSION

Type	Infinitely variable hydrostatic drive with variable displacement pump
Drive pump	Mechanical
Engine to pump ratio	Direct drive 1:1
Type	Variable displacement bi-directional axial piston pump with manual displacement control
Displacement (cc/rev)	75
Flow @rated engine (lpm)	156
Charge pressure (bar)	27

Drive motors

Type	Low speed high torque drive motor mounted on front drum frame along with rear axle motor
Hydraulic oil filter	Cartridge
Axle	Heavy duty with integrated parking brake mechanism and outboard planetary
Parking brake	Spring applied hydraulically released
Engagement	Operate on /off parking brake switch on instrument panel, engine stop

Machine speed:

- Working speed (km/h)	0-5.5
- Travel speed (km/h)	0-11.5
Final drive	High torque outboard planetary

Gradeability

With drum drive (%)	36 (20°)
Intermittent (%)	40

INSTRUMENTATION

Indicators	Parking brake, High/Low beam, Battery not charging, Two speed, Pre heater, Turn signal Left/Right, Neutral
Gauges	Digital hour meter, Water temp, Fuel level, Engine rpm
Warning lights/alarms	Coolant overheat, Hydraulic oil filter clog, Low lube oil pressure, Air filter clog

STANDARD EQUIPMENT

Sun roof, Horn, Front and rear working lights, 90° rotating operator seat, HVAC Cabin, Tilting engine hood, Vandal guard, IP67 weather proof rocker switches, Instrument cluster, Glove box for operator, Easy split design of canopy legs for transportation, 32 mm drum shell thickness.
1110 EX - PD: Drum is mounted with 144 Pads, offering a total pad contact area of 413 sq. cm.

SPECIFICATIONS

GENERAL DIMENSIONS

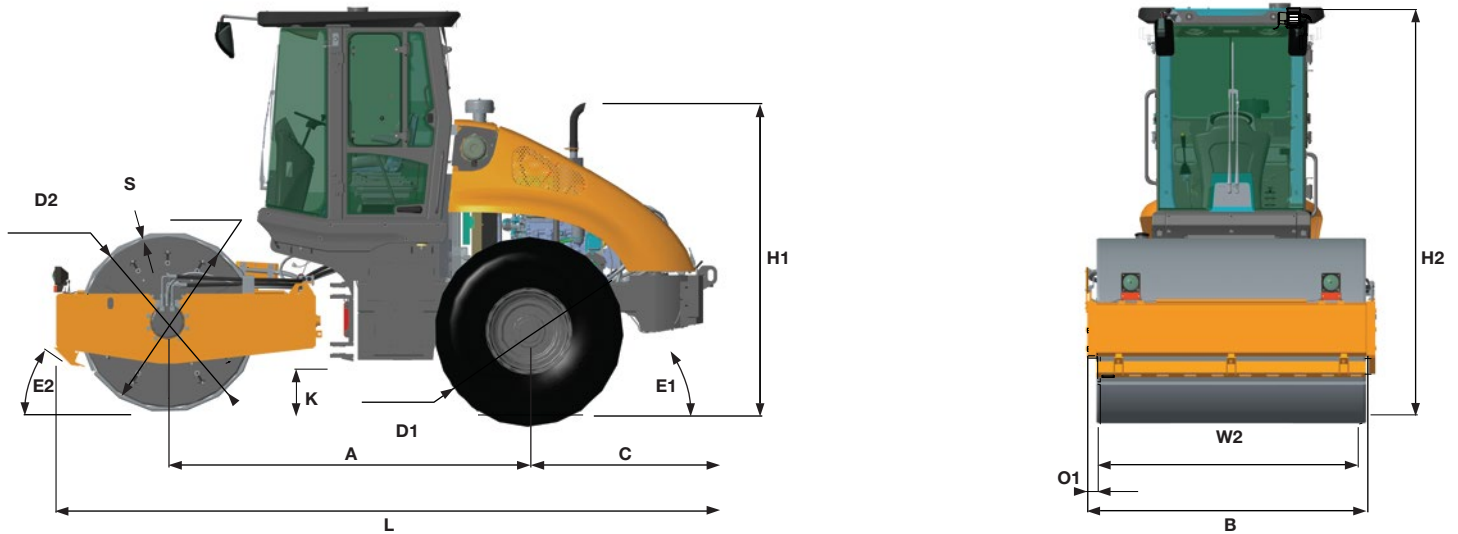

DIMENSIONS

A	Horizontal distance from drum center to tyre center	3003 mm
B	Overall width of the machine	2324 mm
C	Rear overhang	1562 mm
D1	Diameter of the rear tyres	1528 mm
D2	Diameter of the drum	1500 mm
H1	Height of silencer from ground level	2561 mm
H2	Overall height of the machine (in transport)	3373 mm
K	Ground clearance	382 mm
L	Overall length of the machine	5508 mm
O1	Side overhang	87 mm
S	Drum shell thickness	32 mm
W2	Overall width of the drum	2150 mm
E1	Rear departure angle	36 mm
E2	Front departure angle	35 mm

OPERATING DATA

	1110 EX-D	1110 EX-PD
Operating weight	11720 kg	13150 kg
Max. operating weight	13120 kg	14550 kg
Front axle load	6790 kg	8220 kg
Rear axle load	4930 kg	4930 kg
Static linear load front	31 kg/cm	(-)

VIBRATION SYSTEM

	1110 EX-D		1110 EX-PD
Vibration Stage	1	2	1
Frequency	31 Hz	34 Hz	31 Hz
Amplitude	1.8 mm	0.8 mm	1.3 mm
Centrifugal force	27965 kg	16186 kg	25830 kg
Max. applied force	34755 kg	22976 kg	34050 kg

OPTIONAL EQUIPMENT

- Compaction Meter

CaseCE.com
EXPERTS FOR THE REAL WORLD
SINCE 1842

CASE
CONSTRUCTION



Corporate Identity Number: U29240DL1998PTC344616
CASE NEW HOLLAND CONSTRUCTION EQUIPMENT (INDIA) PRIVATE LIMITED
Level-4, Rectangle-1, D-4
District Center, Commercial Complex
Saket, New Delhi - 110017
Contact No.: 011-66544151 | Email:caseindia@cnhind.com

NOTE: Standard and optional fittings can vary according to the demands and specific regulations of each country. The illustrations may include optional rather than standard fittings - consult your CASE dealer. Furthermore, CNH Industrial reserves the right to modify machine specifications without incurring any obligation relating to such changes. Conforms to directive 2006/42/EC
Disclaimer: 2.5% variation on parameters may occur and is acceptable by the industry norms

CASE Customer Assistance
1800 4199 770

