

TECHNICAL DATA

SINGLE DRUM ROLLERS

BW 177 D-5, BW 177 DH-5, BW 177 PDH-5

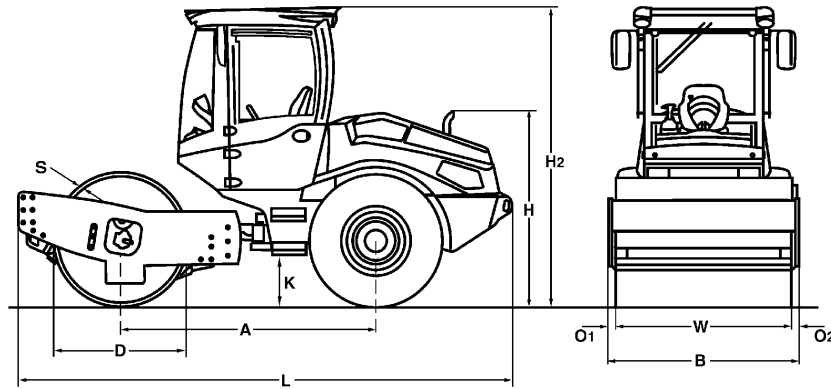



Dimensions in inch

	A	B	D	H	H2	K	L	O1	O2	S	W
BW 177 D-5	92.5	71.7	48.4	68.9	110.2	15.0	179.1	2.6	2.6	0.79	66.5
BW 177 DH-5	92.5	71.7	48.4	68.9	110.2	15.0	179.1	2.6	2.6	0.79	66.5
BW 177 PDH-5	92.5	71.7	47.6	68.9	110.2	15.0	179.1	2.6	2.6	0.59	66.5

Shipping dimensions in cub.yd

BW 177 D-5
BW 177 DH-5
BW 177 PDH-5

without ROPS

18.961
18.961
18.961

with ROPS

30.326
30.326
30.326

Machine type	Compaction output (cub.yd/h)			
	Rock fill	Gravel, sand	Mixed soil	Silt, clay
BW 177 D-5	-	274.7-549.3	209.3-418.5	91.6-183.1
BW 177 DH-5	-	274.7-549.3	209.3-418.5	91.6-183.1
BW 177 PDH-5	-	274.7-549.3	209.3-418.5	124.3-248.5

Machine type	Compacted layer thickness (m)			
	Rock fill	Gravel, sand	Mixed soil	Silt, clay
BW 177 D-5	0.0--	0.45	0.35	0.15
BW 177 DH-5	0.0--	0.45	0.35	0.15
BW 177 PDH-5	0.0--	0.45	0.35	0.20

Technical Data**BOMAG
BW 177 D-5****BOMAG
BW 177 DH-5****BOMAG
BW 177 PDH-5****Weights**

Grossweight	lb	17,196	18,078	16,755
Operating weight CECE w. ROPS-cabin	lb	14,551	14,771	15,322
Axle load, drum CECE	lb	8,819	8,929	9,480
Axle load, wheels CECE	lb	5,732	5,842	5,842
Static linear load CECE	lb/in	132.5	134.2	

Dimensions

Working width	in	66.5	66.5	66.5
Track radius, inner	in	117.1	117.1	117.1

Driving Characteristics

Speed (1)	mph	0- 2.8	0-6.2	0-6.2
Speed (2)	mph	0- 3.4		
Speed (3)	mph	0- 4.7		
Speed (4)	mph	0- 6.5		
Max. gradeability without/with vibr.	%	49/46	61/58	61/58

Drive

Engine manufacturer		Kubota	Kubota	Kubota
Type		V3307 CR-T	V3307 CR-T	V3307 CR-T
Emission stage		Stage V / TIER4f	Stage V / TIER4f	Stage V / TIER4f
Exhaust gas aftertreatment		DOC+DPF	DOC+DPF	DOC+DPF
Cooling		Liquid	Liquid	Liquid
Number of cylinders		4	4	4
Performance ISO 3046	kW	55.4	55.4	55.4
Performance SAE J 1995	hp	75.0	75.0	75.0
Speed	rpm	2,400	2,400	2,400
Fuel		Diesel	Diesel	Diesel
Electric equipment	V	12	12	12
Drive system		hydrost.	hydrost.	hydrost.
Drum driven		standard	standard	standard

Drums and Tires

Tire size		14.9-24/8PR	14.9-24/8PR	14.9-24/8PR
-----------------	--	-------------	-------------	-------------

Brakes

Service brake		hydrost.	hydrost.	hydrost.
Parking brake		hydromec.	hydromec.	hydromec.

Steering

Steering system		oscil.artic.	oscil.artic.	oscil.artic.
Steering method		hydrost.	hydrost.	hydrost.
Steering / oscillating angle +/-	deg	35/12.0	35/12.0	35/12.0

Exciter system

Drive system		hydrost.	hydrost.	hydrost.
Frequency (1)	vpm	29	29	29
Frequency (2)	vpm	32	32	32
Amplitude	in	0.075/0.032	0.075/0.032	0.069/0.035
Centrifugal force	lb	25,179/16,636	25,179/16,636	25,179/16,636

Capacities

Fuel	gal	29.1	29.1	29.1
------------	-----	------	------	------

Technical modifications reserved. Machines may be shown with options.

Standard Equipment

- BOMAG ECOMODE
- Double pump system for travel drive (DH/PDH)
- No-Spin differential lock
- Rear axle with twin spring accumulator brakes
- Hydrostatic travel and vibration drive
- Hydrostatic articulated steering
- Articulated joint lock
- Warning, information and operation displays
- Single lever control for travel and vibration
- Emergency STOP
- Warning horn
- Back-up warning system
- Noise insulation
- 2 Contact scrapers Plastic (D/DH)
- 2 Scrapers (PDH)
- Tractor tires (PDH)

Optional Equipment

- * ROPS cabin with seat belts
- ROPS/FOPS with safety belt
- Tractor tires (D/DH)
- * Working lights front/rear
- Indicator and hazard lights
- Rotary beacon
- Rearview camera
- Air condition
- Adjustable steering column
- Sliding window
- Radio (Bluetooth)
- BOMAG ECOSTOP
- ECONOMIZER
- TERRAMETER
- Printer for TERRAMETER
- BOMAG TELEMATIC
- BCM 05 Documentation system
- Special painting
- Reversing alarm buzzer with broad band audio
- Padfoot segment kit (D/DH)
- Dozer blade (DH/PDH)
- Environmentally compliant hydraulic oil
- Measuring- and machine data interface for third-party suppliers
- LED Working lights (Cabin)

* Standard delivery with CE conformity
(valid within European Union)

