



Machines

Articulated rollers

RW 1800 / RW 3005 / RW 5005



RW 1800

RW 1800-SPT: Compact dimensions for various applications





Universal compaction application

Individual

A roller, specially designed according to the wishes of the customer? This is not a great dream, this is reality with Rammax. The modular structure of our rollers allows the customer to arrange his machine individually according to his needs.

Basic concept

- An articulated roller has to fulfil very different applications. Ideal compaction results need to be achieved in short time while considering different soil types, varying civil works and permanent changing labour. Therefore the demands of the customer on the equipment are enormous and very different.
- With the objective of including all wishes in the development of the rollers the current product line was made possible.
- Therefore these machines are available in different sizes and designs. The customer has the possibility to compose the roller considering his requests.
- With smooth drum or pad foot drum, with dozer blade or with the optional smooth drum segments, whereby the pad foot drum can be converted into a smooth drum.

RW 1800

- The RW 1800 features an enormous hydraulic performance. Two separate pumps supply the hydraulic motors in the drum and the two wheel motors.
- The serial float divider for both rear wheels works like a differential lock and prevents the rear wheels from spinning.
- The compact dimensions of this machine allow its use for almost unlimited applications; such as in trenches, development areas or road construction.

Dozer blade

- Equipped with a hydraulic dozer blade, the roller can be used for backfilling and compaction work without additional earth moving equipment.
- In combination with the tilt function on the blade the machine is capable of preparing a perfect plane surface followed by compaction with the same machine.

Available versions

- RW1800 - with smooth drum
- RW 1800-PT - with smooth drum and 4-way dozer blade
- RW 1800-S - with pad foot drum
- RW 1800-SPT - with pad foot drum and 4-way dozer blade



Clearly arranged cockpit

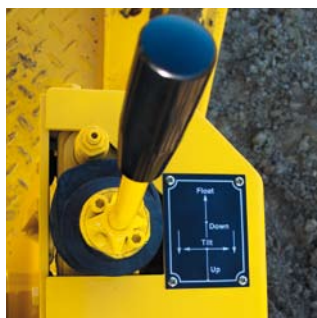

Blade operation



Engine



4-way dozer blade



RW 3005 and RW 5005

RW 3005-SPT: Universal machine for various applications

RW 5005: Compact machine with high performance





Universal compaction application

RW 3005 / 5005

- New hydraulic concept by the use of the „Twin-Lock“-system. This is a fully automatic traction management system with a completely mechanical mode of operation. In case of slip in one of the drive components, the torque is automatically and steplessly forwarded to the remaining drive systems.
- The machine only stops when both drive wheels and the drum are without traction. As a result a maximum gradeability on every site is reached.

Comfort

- Generously dimensioned drivers platform mounted on completely vibration-free bearings. This effectively eliminates the transmission of vibrations and stress to the driver.
- One-hand operation of all blade functions and vibration functions.
- Clearly arranged cockpit and simple operation guarantee effective utilization.

Dozer blade RW 3005-SPT

- Equipped with a hydraulic dozer blade, the roller can be used for backfilling and compaction work without additional earth moving equipment.
- In combination with the blade tilt function (4-way blade) the machine is capable of preparing a plane surface followed by compaction with the same machine.

RW 5005

The RW 5005 was developed on the basis of the RW 3005.

Therefore we were able to realize an extremely compact roller compared to the weight class of the machine. Due to the small dimensions and the resulting agility the machine outstands also on smaller civil works with its maximum performance.

Variable

- The RW 5005 is serially equipped with a variable compaction output. Hereby it is possible to switch between two options:
 - 1)Combination of low frequency with high amplitude und compaction force
 - 2)Combination of high frequency with lower amplitude and compaction forceThe roller can be adapted to various soil types and fields of application.
- On the RW 5005-S the setting of the rotating direction of the eccentric shaft can be switched. The gradeability and compaction output on slopes can be optimized with this function.

Cabin

- Both RW 3005 and RW 5005 have ROPS driver platforms as basic version. Optionally a closed cabin with heating, heatable rear window and front and rear working lights are available.



Modern, clearly arranged cockpit



Control lever



Engine



4-way dozer blade (RW 3005-SPT)

Technical data

		RW 1800	RW 3005	RW 3005	RW 5005	RW 5005-S
Type		S / SP / SPT	S / SPT	smooth drum	smooth drum	pad foot drum
Working width	mm	1000 / 1100 / 1100	1200 / 1426	1200	1400	1400
Weight						
Operation weight	kg	1800 / 2000 / 2100	3400	3150	4800	4800
Axle load front	kg	1000 / 1200 / 1200	1900	1650	2600	2600
Axle load rear	kg	800	1500	1500	2200	2200
Static line load	kg/cm	11,1 / 13,3 / 13,3	15,8	13,3	19,2	19,2
Dynamic line load	kg/cm	71,1	70,8	70,8/24,2	71,4	71,4
Engine						
Manufacturer/type		Kubota D 1403	Kubota V 2203	Kubota V 2203	Kubota V 3300	Kubota V 3300
Power	kW/HP	19,9 / 27	36,4 / 19,5	36,4 / 49,5	50,7 / 68,9	50,7 / 68,9
At rpm		2800	3000	3000	2650	2650
No. of cylinders / cooling		3 / water cooled	4 / water cooled	4 / water cooled	4 / water cooled	4 / water cooled
Drive system		hydrostatic	hydrostatic	hydrostatic	hydrostatic	hydrostatic
Vibration system						
Centrifugal force	kN	64	85	85 / 29	100 / 50	100
Amplitude	mm	1,6	1,8	1,6 / 0,9	1,8 / 0,8	1,8
Frequency	Hz	34	34	34	34 / 41,6	34
Drive system		hydrostatic	hydrostatic	hydrostatic	hydrostatic	hydrostatic
Filling capacities						
Fuel	l	35	64	64	64	65
Hydraulic oil	l	138	140	140	139	139
Driving qualities						
Speed (continuous variable)		0 - 7	0 - 7	0 - 7	0-10	0-10
Steering		Articulation	Articulation	Articulation	Articulation	Articulation
Articulation angle	+/- °	35	30	30	30	30
Gradeability w / w/o vibration	%	45 / 50	55	45	40	40
Dimensions	mm	A (Length)	B (Width)	C (Height)	D (Drum width)	E (Drum diameter)
RW 1800 S		2740	1300	2265	900	790
RW 1800 SP		3110	1400	2265	900	790
RW 1800 SPT		3200	1400	2265	900	790
RW 3005		3500	1300	2470	1200	890
RW 3005 SPT		4010	1420	2470	1200	890
RW 5005		4030	1542	2480	1400	1070

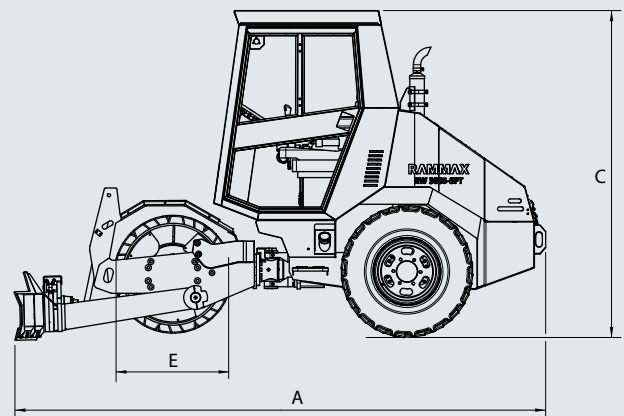
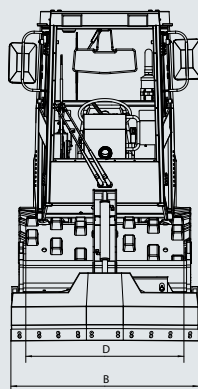



Overview details

Hydraulic dozer blade with tilt function

Closed cabin with heating and working lights

Ideal visibility for the driver

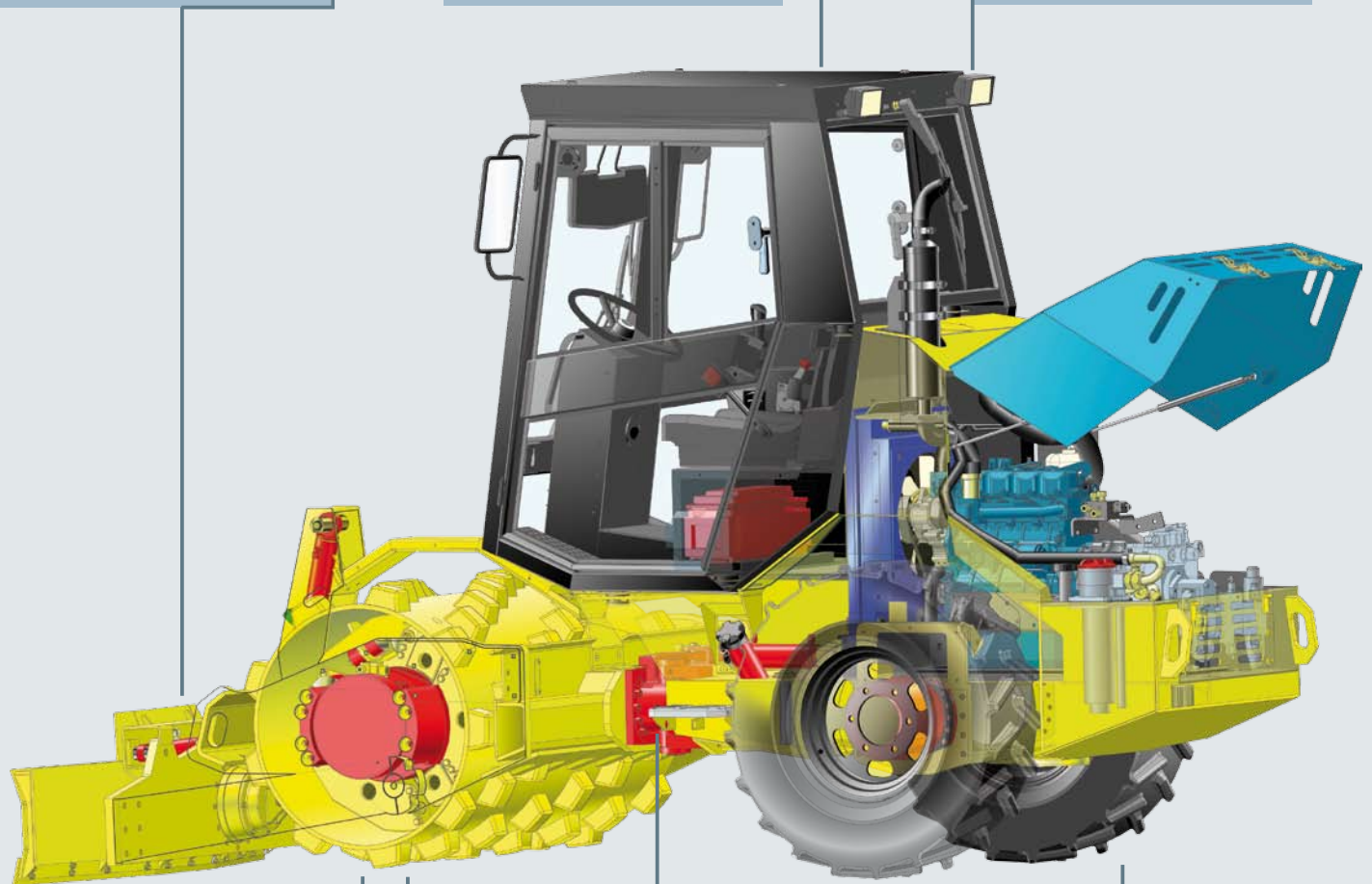

Complete side clearance due the hose guiding inside the frame

Low center of gravity

„Twin lock“ traction control

Articulation

„Twin lock“ traction control

Ammann distribution
companies:

Switzerland:
Ammann Schweiz AG
CH-4901 Langenthal
Tel +41 62 916 61 61
Fax +41 62 916 65 40

Germany:
Ammann Verdichtung GmbH
D-53773 Hennef
Tel +49 22 42 880 20
Fax +49 22 42 880 259

Rammax Maschinenbau GmbH
D-72555 Metzingen
Tel +49 71 23 922 30
Fax +49 71 23 922 350

Czech Republic:
Ammann Czech Republic a.s.
CZ-54901 Nové Město nad Metují
Tel. +420 491 476 111
Fax +420 491 470 215

France:
Ammann France SA
F-94046 Créteil/Cedex
Tel +33 1 45 17 08 88
Fax +33 1 45 17 08 90

United Kingdom:
Ammann Equipment Ltd.
GB-Warwickshire, CV37 0TY
Tel +44 1789 414 525
Fax +44 1789 414 495

Poland:
Ammann Polska sp.zo.o.
PL-02-230 Warszawa
Tel +48 22 33 77 900
Fax +48 22 33 77 929

USA:
Ammann America Inc.
US-Ponte Vedra, Florida 32082
Tel +1 904 543 1691
Fax +1 904 543 1781

Ammann manufacturing
companies:

Switzerland:
Ammann Schweiz AG
CH-4901 Langenthal
Tel +41 62 916 61 61
Fax +41 62 916 64 03

Germany:
Ammann Verdichtung GmbH
D-53773 Hennef
Tel +49 22 42 880 20
Fax +49 22 42 880 259

Rammax Maschinenbau GmbH
D-72555 Metzingen
Tel +49 71 23 922 30
Fax +49 71 23 922 350

Czech Republic:
Ammann Czech Republic a.s.
CZ-54901 Nové Město nad Metují
Tel. +420 491 476 111
Fax +420 491 470 215

